



KURODA



SG, SE and SC Linear Actuators

- STOCK Items defined
- Repeat Positioning Accuracy +/- 1 micron
- Shaft Diameters and Leads 1mm to 20mm

Contact Us! 800-433-3434 USA

Email info@grp6.com

CONTENTS

Ballscrew Actuators	Front Matter 2
Features of SG/SE Series	Front Matter 3
Key Components and Materials of SG and SE Series	Front Matter 4
Features of SC Series (Full-Cover Type)	Front Matter 5
Key Components and Materials of SC Series	Front Matter 6
Variations of Slide Block	Front Matter 7
Summary of Accuracy Indicators	Front Matter 8-10
Rigidity	Front Matter 11
Option and Manufacturing by Order	Front Matter 12
How to Interpret Model No.	Front Matter 13
For Safety Use	Front Matter 14
Ballscrew Actuator/Common Instructions	Front Matter 15
High Accuracy Ballscrew Actuators/SG Series Contents	1
Variations, Model No.	2
Specifications	3
Accuracy	4
Inertia	5
SG20 Dimensions	6-13
SG26 Dimensions	14-21
SG33 Dimensions	22-33
SG46 Dimensions	34-43
SG55 Dimensions	44-50
High Rigidity Ballscrew Actuators/SE Series Contents	51
Variations, Model No.	52
Specifications	53
Accuracy	54
Inertia	55
SE15 Dimensions	56-61
SE23 Dimensions	62-69
SE30 Dimensions	70-77
SE45 Dimensions	78-87
Full-Cover Type Ballscrew Actuators/SC Series Contents	89
Variations, Model No.	90
Specifications	91
Accuracy	92
Inertia	93
SC23 Dimensions	94-97
SC30 Dimensions	98-101
SC45 Dimensions	102-105
Sensor Specifications	106-108
Technical Data For Ballscrew Actuators	109-119

BALLSCREW ACTUATORS

A ballscrew actuator of KURODA is a compact single-axis unit consisting of a ball screw and a slide guide. With its slide block set in U-guide rail, the actuator has achieved low-profile design and compact shape, making it possible to considerably reduce necessary space as compared with the usual table type structure. Despite of its compact structure, the actuator with U-guide rail shows high rigidity against bending moment and deflection, and it can be applied to a structure supported by one end. The linear motion unit, which is gothic arched and in 4 points-contact structure, makes it possible to deliver high precision and high rigidity.

Front matter

POSITIONS OF BALLSCREW ACTUATORS

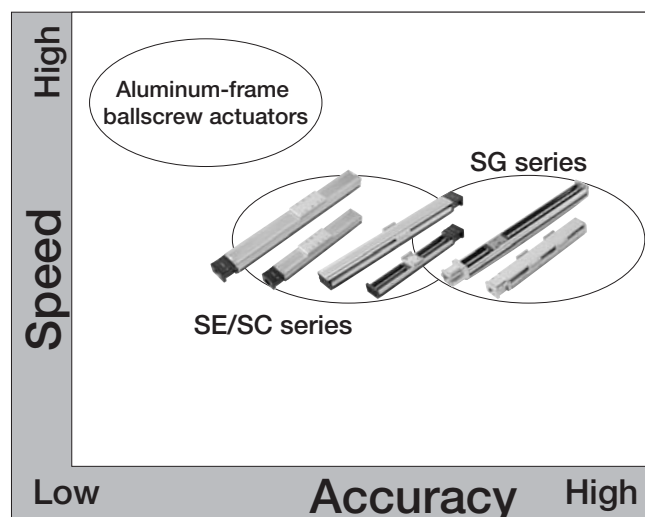
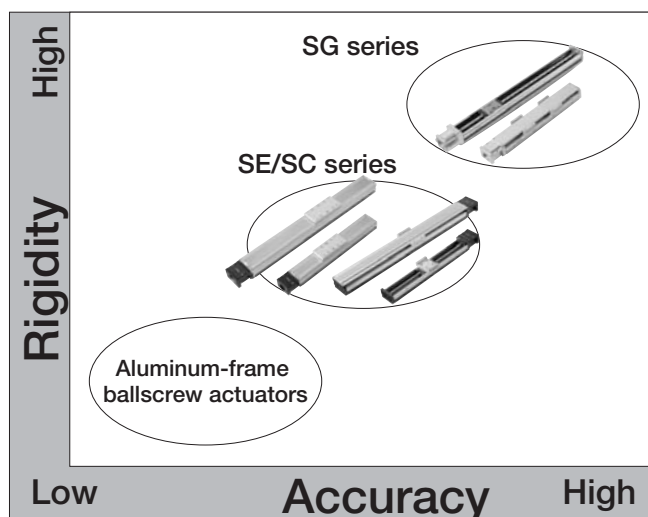

WIDE VARIATIONS

Model No.	SG series						SE series				SC series (Note 2)		
	SG20	SG26	SG33	SG3320	SG46	SG55	SE15	SE23	SE30	SE45	SC23	SC30	SC45
Performance grade (Note 1)	P: Repeated positioning accuracy $\pm 1 \mu\text{m}$ H: Repeated positioning accuracy $\pm 3 \mu\text{m}$						U: Repeated positioning accuracy $\pm 5 \mu\text{m}$ W: Repeated positioning accuracy $\pm 10 \mu\text{m}$						
Screw shaft dia. (mm)	6	8	10	12	15	20	6	8	10	15	8	10	15
Lead (mm)	1	○					○						
	2		○	●			○	○	●		○	●	
	4							●	○		●	○	
	5	○	○	○		●	●	○	○	○	○	○	○
	8								●		●		
	10			○		○	●			○	○		○
20				○	○	○			○				○

○ : In-stock items ● : Manufactured by order

(Note 1) The above table shows precision information on repeated positioning accuracy in particular, as an example.

Performance of actuators may be different from the values shown above, depending on applied options and usage.

For other precision information, refer to description pages for each series.

(Note 2) SC series is a full-cover version of SE series ballscrew actuators.

For more information, refer to front matter 5, pages 6 and 89 to 105.

FEATURES OF SG/SE SERIES

■ No necessity for adjustment

Ball screw and slide guide are integrated in ballscrew actuator, eliminating the need for complicated fine adjustment and reducing the number of working processes to a great extent.

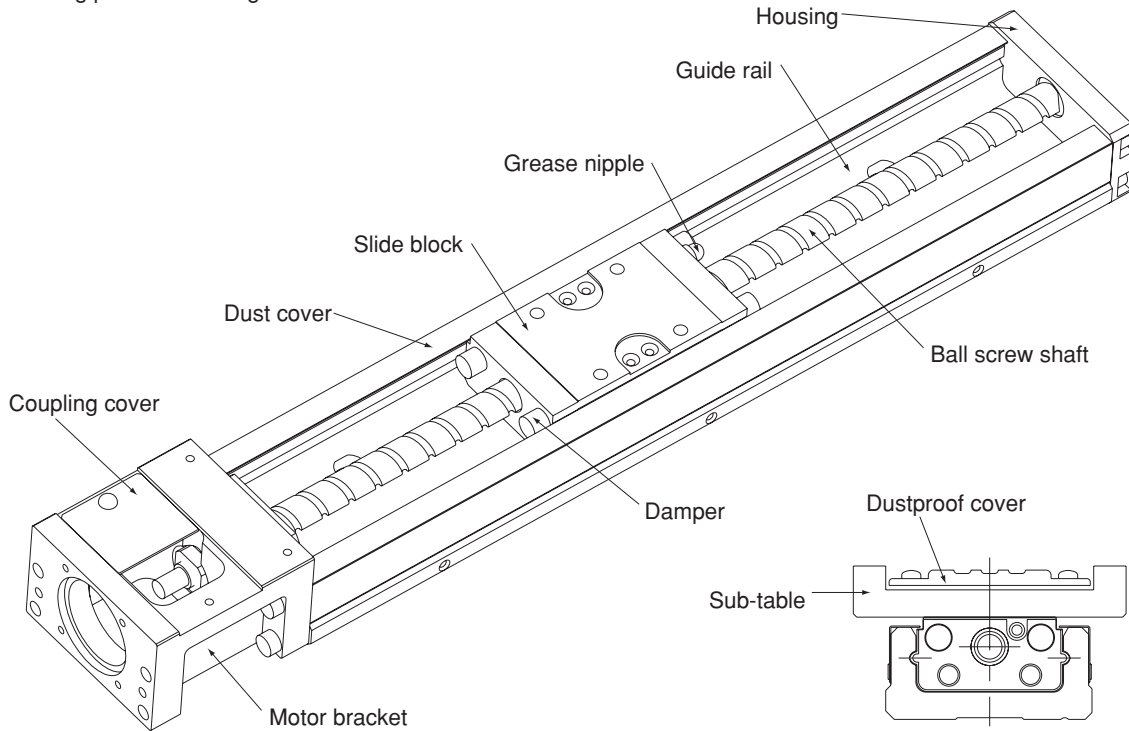

Front matter

■ High rigidity

With U-guide rail, rigidity of ballscrew actuator has remarkably improved despite of its compact structure, making it possible to be applied even to a structure supported at only one end.

■ High accuracy

Linear motion unit uses "4 or 2 Ballway of 4 points-contact" structure to assure high rigidity. Guide rail, slide block and ball screw shaft are precisely worked, making accurate positioning possible.

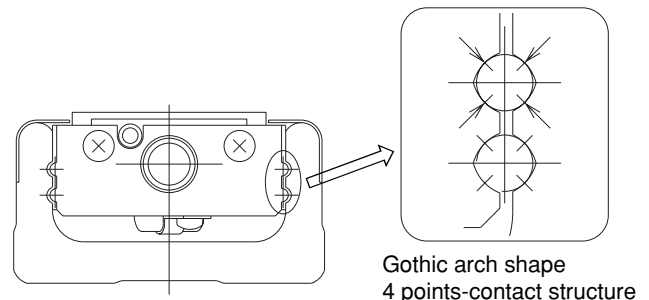

■ Space-saving

With its slide block set in U-guide rail, the actuator has achieved low-profile design and compact shape, making it possible to considerably reduce necessary space as compared with usual table type structure.

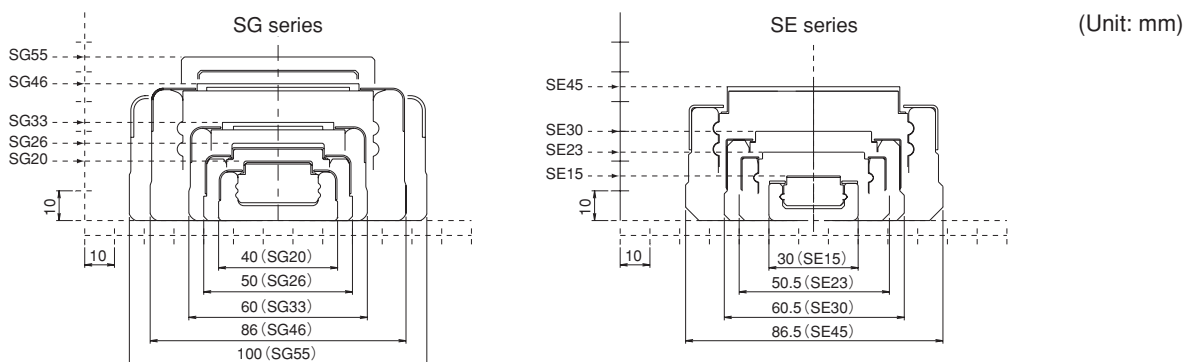

KEY COMPONENTS AND MATERIALS OF SG AND SE SERIES

Front matter

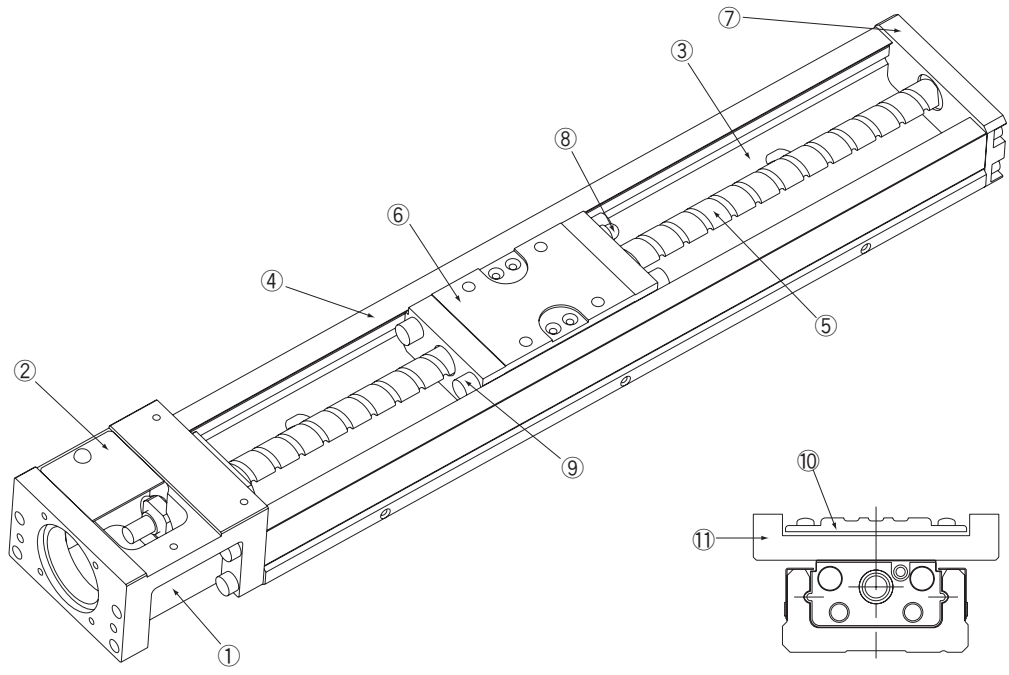

No.	Part name	Material	Remarks
①	Motor bracket	Aluminum alloy	Anodized treatment or baking finish
②	Coupling cover	Aluminum alloy	Anodized treatment
③	Guide rail	Stainless steel (SG20, SG26) Carbon steel(SG33, SG46, SG55, SE15, SE23, SE30, SE45)	Black coating (Note 1)
④	Dust cover	Aluminum alloy	Anodized treatment
⑤	Ball screw shaft	Chromium-molybdenum steel (SG series) Carbon steel (SE series)	
⑥	Slide block	Chromium-molybdenum steel	
⑦	Housing	Aluminum alloy	Anodized treatment or baking finish
⑧	Grease nipple	Stainless steel	
⑨	Damper (Note 2)	Synthetic rubber	
⑩	Dustproof cover	Aluminum alloy	Anodized treatment
⑪	Sub-table	Aluminum alloy	Anodized treatment

(Note 1) Guide rails made from stainless steel are not surface-treated.

(Note 2) Damper position of SG series is different from SE series. For more information, refer to dimensions of each series.

(Note 3) Stainless steel is used for bolts and machine screws to joint components of actuator.

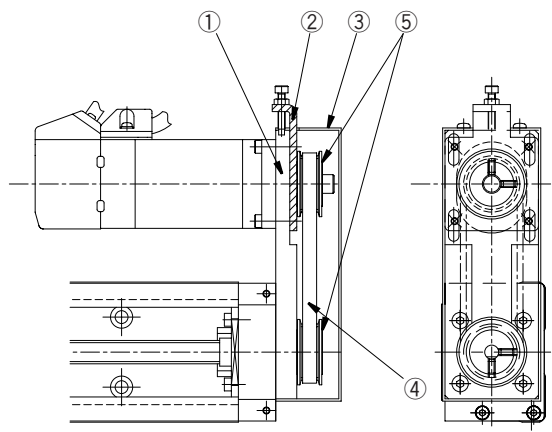

No.	Part name	Material	Remarks
①	Motor mounting plate	Rolled steel	Black coating
②	Tension plate	Stainless steel	
③	Pulley cover	Stainless steel (SG series) Cold-rolled steel plate (SE/SC series)	Anti corrosive black coating (Note 2)
④	Timing belt	Resin	
⑤	Timing pulley	Aluminum alloy	

(Note 1) Stainless steel is used for tension bolts and nuts.

(Note 2) Anti corrosive black coating of pulley cover applies to SE and SC series.

FEATURES OF SC SERIES (FULL-COVER TYPE)

Full-cover type SC series, built on KURODA SE series, has remarkably improved its dust-preventive performance.

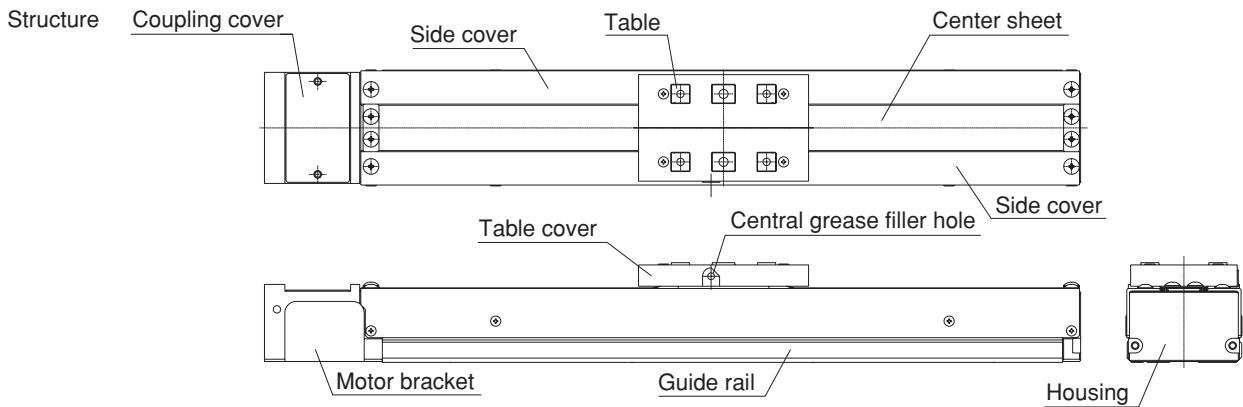

Front matter

Remarkably improved dust prevention!

Compared to SE series with dustproof cover, dust prevention has been remarkably improved through making clearance on side face of actuator as narrow as it can be and effectively applying new center sheet designed to straddle the tables, so as to prevent entry of dust.

Center sheet is a flexible stainless sheet having a structure to keep its position and to prevent it from being lifted.

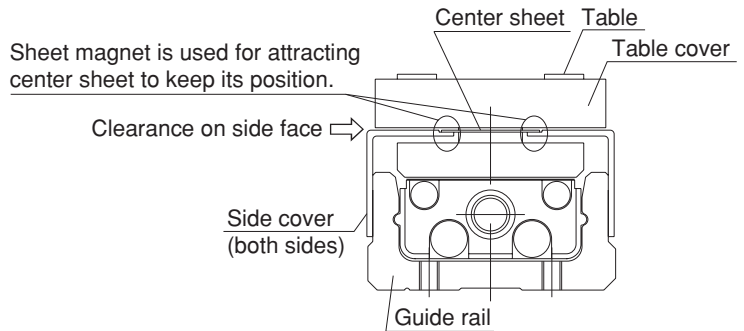

For further improved dust prevention, a wiper can be optionally equipped so that a gap between bottom of table cover and side cover/center sheet is filled.

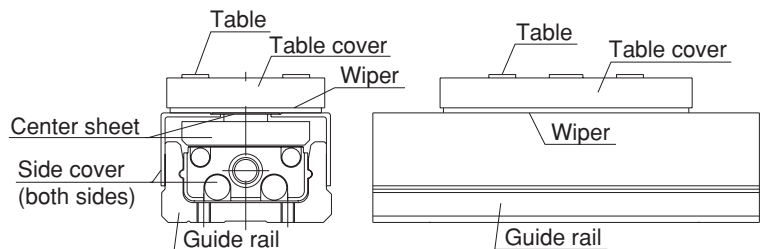

Down-sized body meeting space-saving needs!

SC series has full-cover type body with the same width and dimensions as SE series' guide rail.

Replacing SE series with the full-cover type SC series requires just the same mounting space (width) as SE series (Note that mounting height is different).

Easy maintenance!

In order for more efficient grease-up work, which is usually found cumbersome, a central grease filler hole is provided on the side face of the table, as standard equipment of SC series.

Supplying grease to ball screws and guide parts can be completed at a time through the central grease filler hole. (A plug is equipped with standard spec. model).

Grease nipple to be attached to grease filler hole is available as an option. (For more information, refer to pages 96, 100, and 104.)

Guide with remarkable rigidity!

Having steel U-guide rails similar to SG/SE series, SC series shows high rigidity despite of its compact structure, and it can be applied to a structure supported by one end. (For more information, refer to front matter 11.)

KEY COMPONENTS AND MATERIALS OF SC SERIES

Front matter

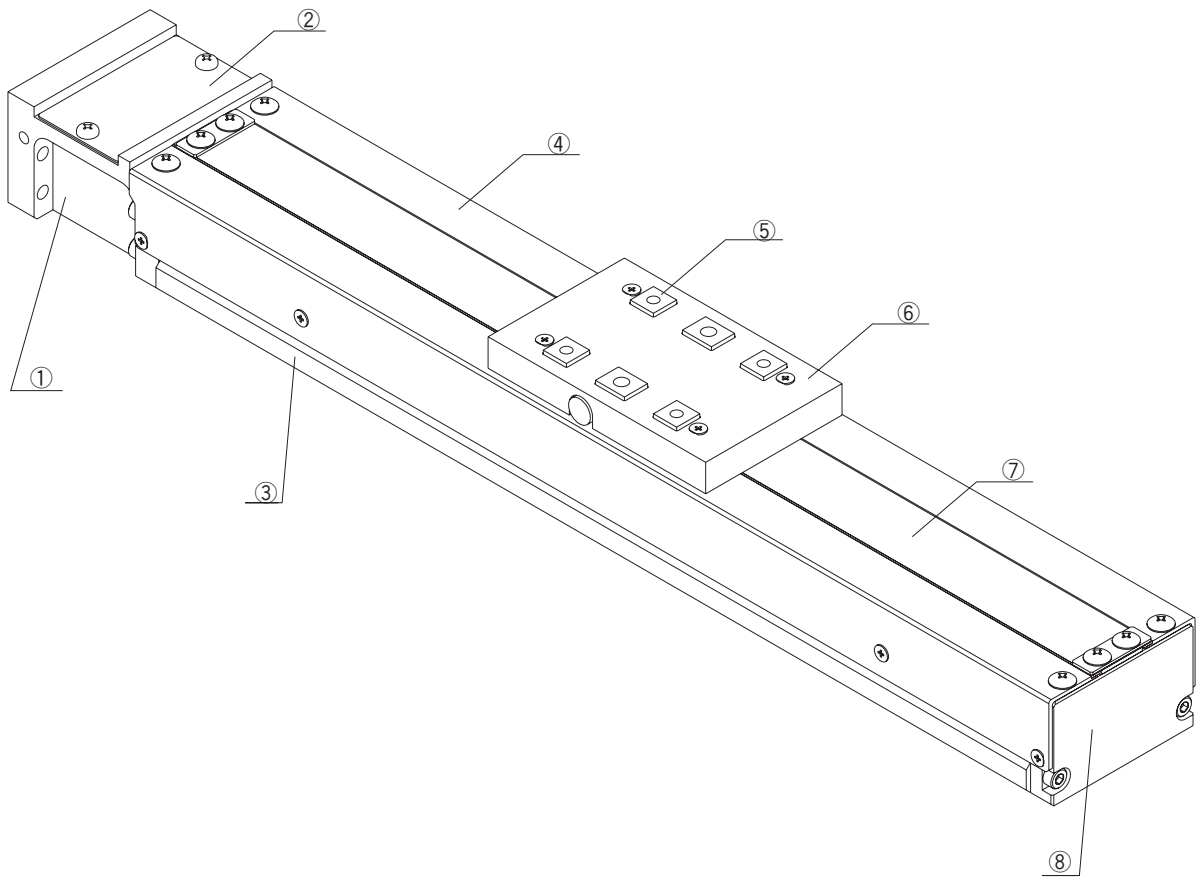

No.	Part name	Material	Remarks
①	Motor bracket	Aluminum alloy	Anodized treatment
②	Coupling cover	Aluminum alloy	Anodized treatment
③	Guide rail	Carbon steel	Black coating
④	Side cover	Aluminum alloy	Anodized treatment
⑤	Table	Aluminum alloy	Anodized treatment
⑥	Table cover	Synthetic resin	
⑦	Center sheet	Stainless steel	
⑧	Housing	Aluminum alloy	Anodized treatment

(Note 1) Ball screws used for SC series have the same specifications as SE series.
 (Note 2) Stainless steel is used for bolts and screws to joint components of actuator.

VARIATIONS OF SLIDE BLOCK

Two types of actuator with long block and short block are available. Additional types with either 2 long blocks or 2 short blocks are also available. Appropriate type can be selected from the variations according to your purpose of use.

Front matter

● With 1 long block: A

Applied to SG, SE, and SC series.

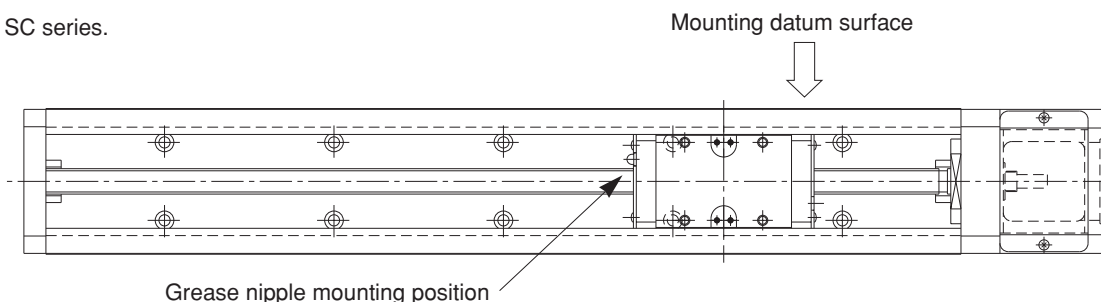

● With 2 long blocks: B

Applied to SG and SE series. (Not available for SC series.)

This configuration may not be applicable depending on guide rail length.

For more information, refer to dimensions of each series.

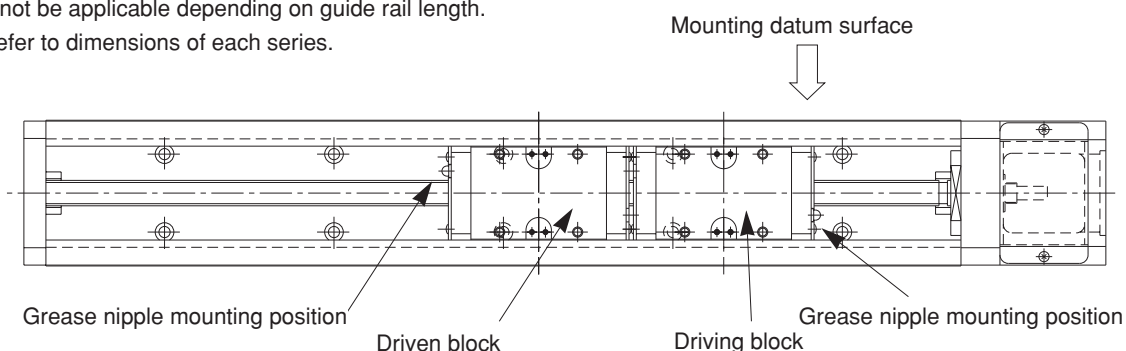

● With 1 short block: C

Applicable size in SE series: SE45

Applicable size in SG series: SG33, SG46

(Not available in SC series.)

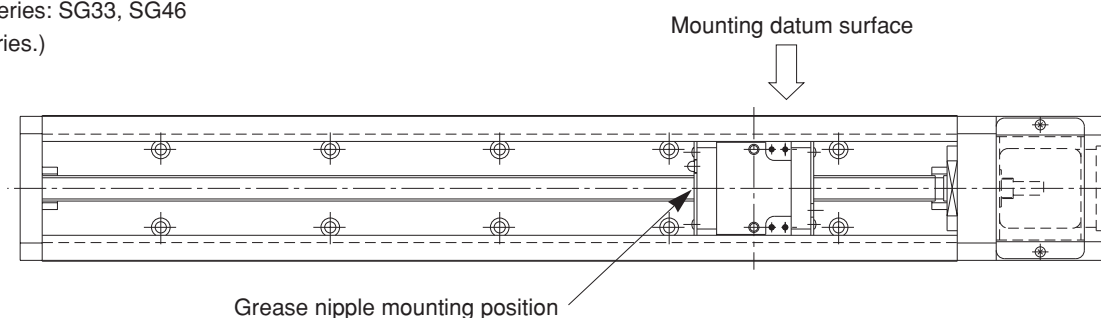

● With 2 short blocks: D

Applicable size in SE series: SE45

Applicable size in SG series: SG33, SG46

(Not available in SC series.)

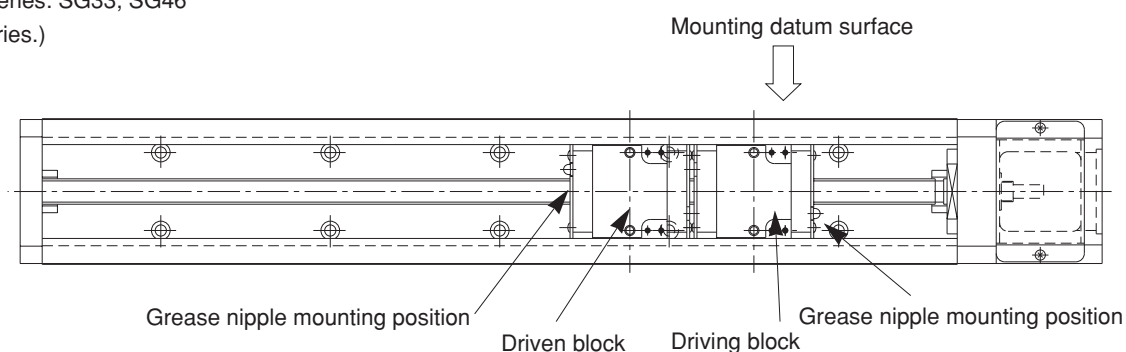

SUMMARY OF ACCURACY INDICATORS

Performance of ballscrew actuators are shown using various accuracy indicators described below.
 For details in tolerance of the accuracy indicators, refer to table of performance (accuracy) information for each series.

Front matter

● Repeated positioning accuracy

Repeat positioning of slide block in the same direction 7 times, measure stop position of slide block and halve maximum difference between obtained readings. Perform this measurement at the center and both ends of travel distance. Maximum value among obtained value is used as measured value.

Repeated positioning accuracy
 $= \pm 1/2 ((\text{maximum value of } \ell_n) - (\text{minimum value of } \ell_n))$

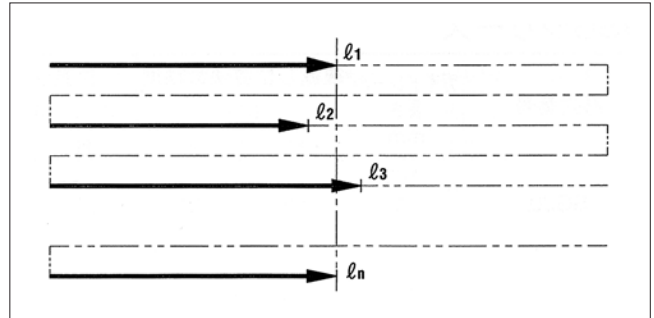

● Positioning accuracy

Position slide block properly in a fixed direction and use the obtained position as datum point. Perform positioning of slide block in the same direction and measure difference between actual travelling distance of slide block from datum point and distance ordered to be traveled from datum point. Perform this measurement throughout stroke range and use maximum value.

Positioning accuracy $= (\Delta \ell_n)_{\text{max}}$

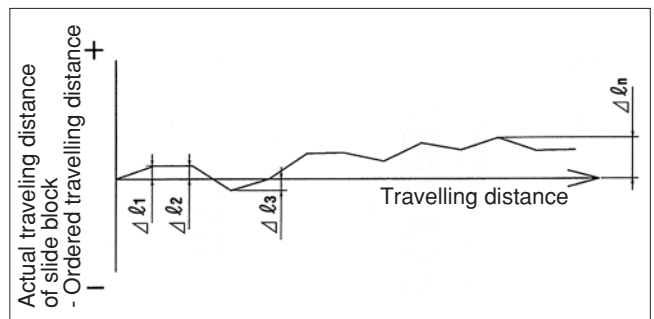

● Traveling parallelism B

Fix indicator at the center of slide block and apply it to surface plate equipped with guide rail. Move slide block throughout traveling distance and use maximum distance among readings of test indicator as measured value.

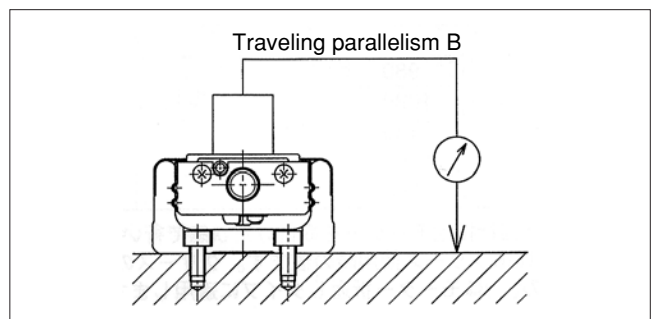

● Backlash

Move slide block by rotating ball screw shaft and read test indicator when slide block is slightly moved and use its reading as reference value. Move slide block from this state in the same direction by pressuring prescribed load and measure difference between reading of test indicator with load removed and reference value. Perform this measurement at the center and both ends of traveling distance and use maximum value as a measured value.

Backlash $= \Delta \ell$

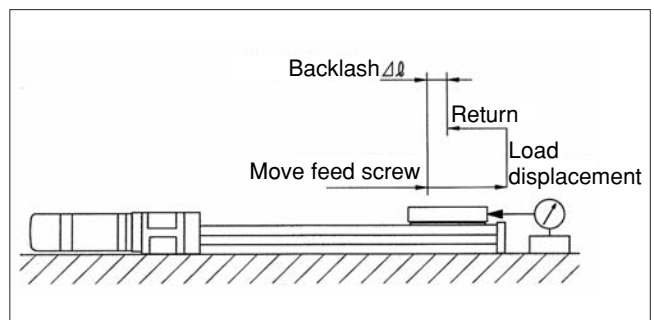

- Firmly tighten the fixed part and connection of the ballscrew actuator.
 Improper mounting of the body may adversely affect safety and accuracy depends on the circumstances.

REFERENCE DATA ON ACCURACY

ACCURACY OF UNIT PRODUCT

Front matter

● Lost Motion

Perform positioning in a positive (or negative) direction and measure the position (l_1). Move the slide block in the same direction and perform positioning in a negative (or positive) direction and measure the position (l_1'). Move it further in the same direction and thereafter repeat the procedure in the positive and negative directions seven times each. Obtain the differences of the average values of the stop positions. Conduct this measurement for the entire moving range and use the obtained maximum value as a measured value.

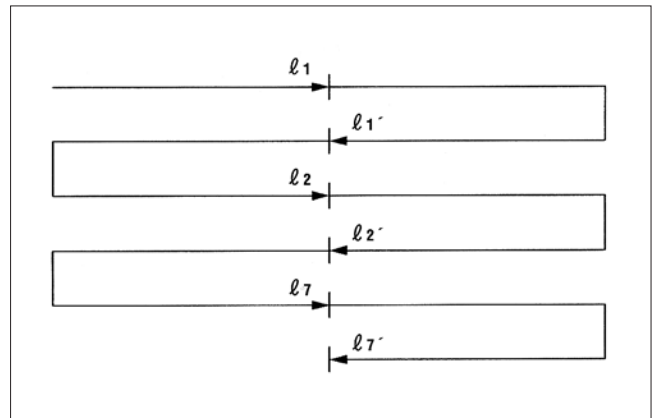

● Traveling Parallelism A

In the case of ballscrew actuators:

Set dial gauge on surface plate, fix indicator on top of slide block, obtain the maximum difference of dial gauge readings in measurable moving range in longitudinal direction of slide block. And use it as a measured value. Since the measurable range is small for ballscrew actuators, Traveling Parallelism B is used as the measurement method for all of the cases except for a few exceptions.

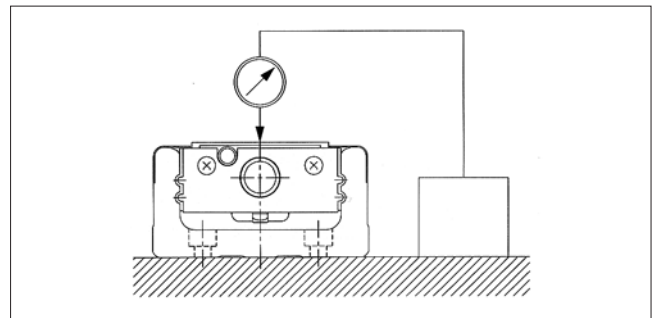

In the case of X-Y stages:

Set dial gauge on surface plate, fix indicator at the center of table, obtain the maximum difference of dial gauge readings in entire moving range in X-Y direction. The maximum difference is used as a measured value.

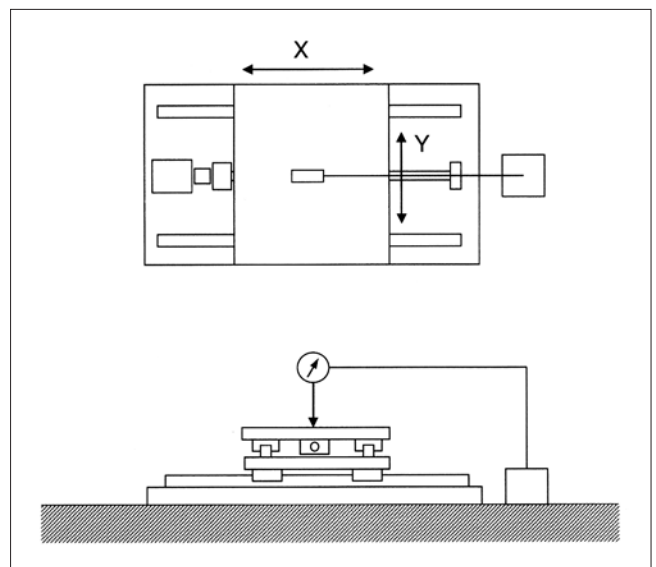

REFERENCE DATA ON ACCURACY

ACCURACY OF UNIT PRODUCT

Front matter

● Squareness

In case squareness cannot be measured on the table top:

Set a dial gauge on the table top. On surface plate close to the table travel range, fix a square gauge in parallel to X (or Y) travel direction.

Place a fix indicator against the side of square gauge parallel to Y (or X) travel direction. The maximum reading value of the dial gauge in the entire travel range is a measured value of squareness.

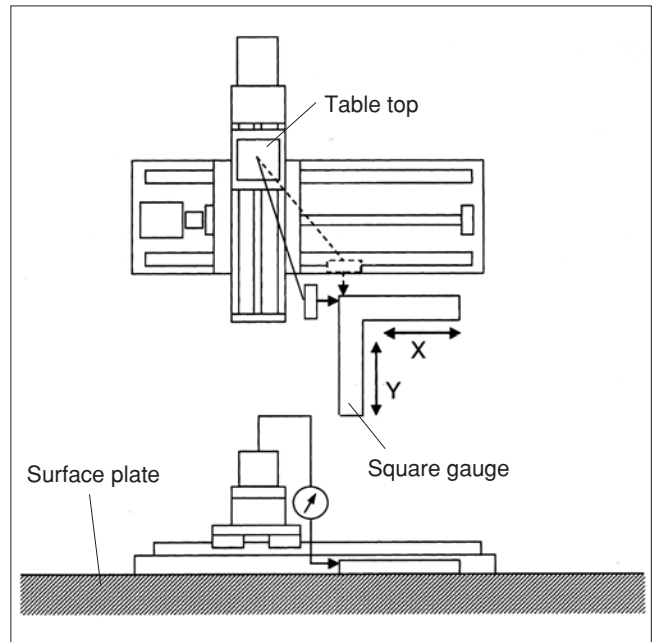

In case squareness can be measured on the table top:

Set a dial gauge on surface plate. On the table top, fix a square gauge in parallel to X (or Y) travel direction.

Place a fix indicator against the side of square gauge parallel to Y (or X) travel direction. The maximum reading value of the dial gauge in the entire travel range is a measured value of squareness.

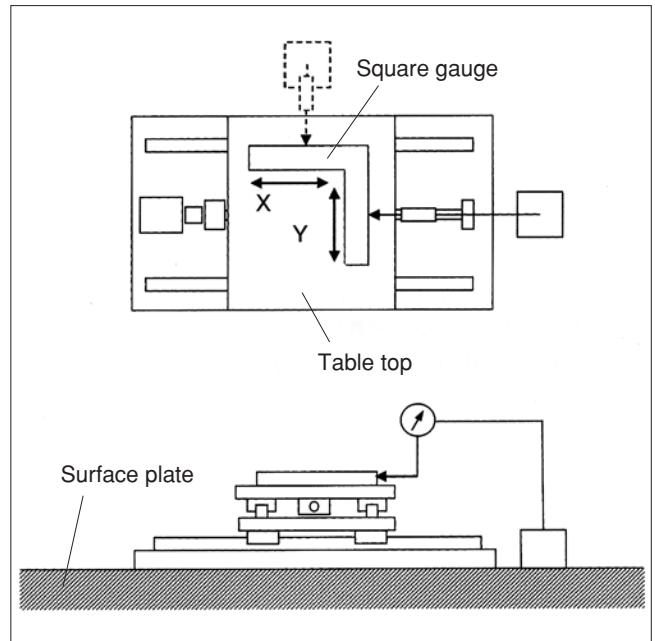

RIGIDITY

Linear motion units of SG, SE, and SC series, having gothic-arched grooves and 4 points-contact structure on guide rails and slide blocks, have attained high rigidity. Displacement by each radial load in each size with long block configuration is shown below as a reference.

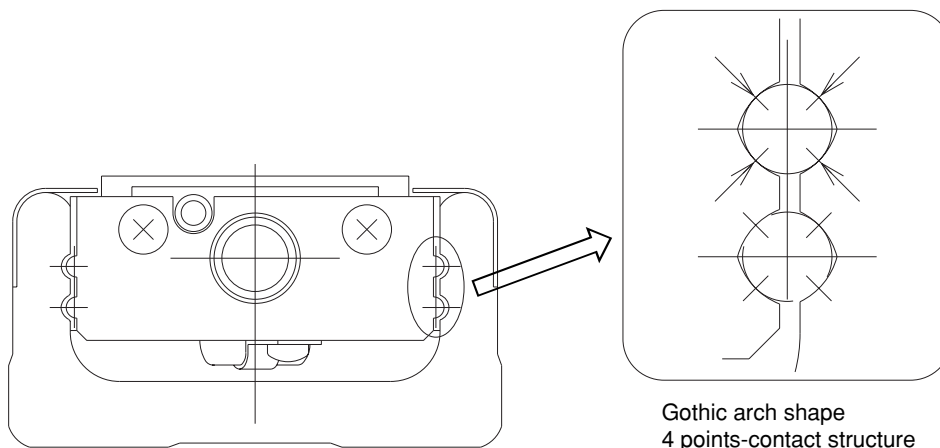

Front matter

● Displacement of Slide block by Radial Load

SG series

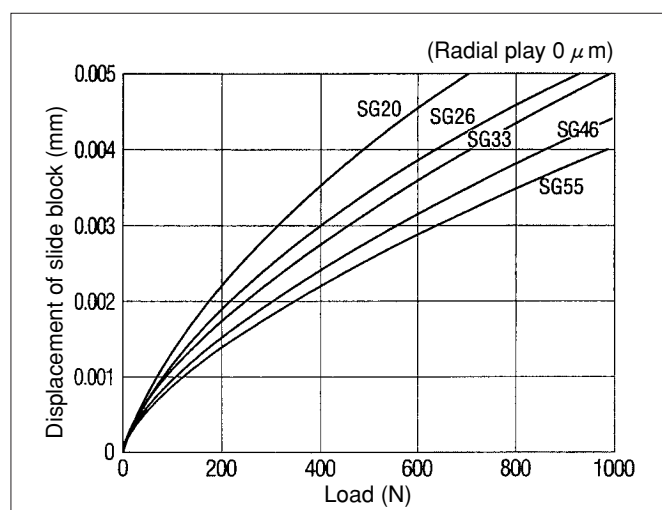

SE/SC series

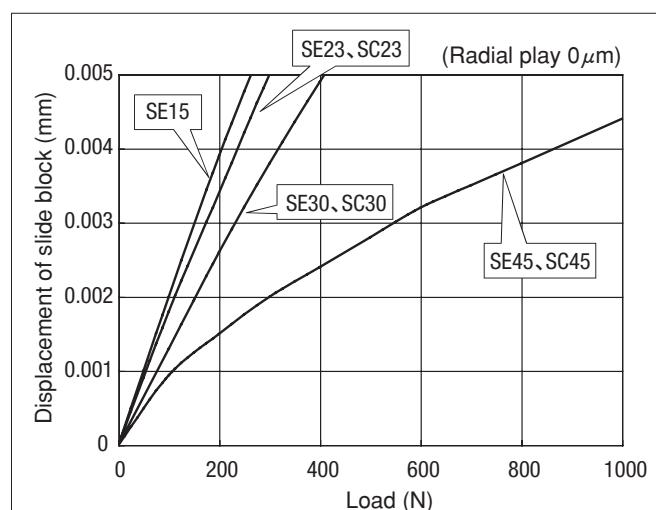

● Sectional Secondary Moment of Guide Rail

The following table shows sectional secondary moments of guide rails in each size.

Model No.	Sectional secondary moments (mm ⁴)		Mass (kg/100mm)
	I _x (X axis)	I _y (Y axis)	
SG20	6.50×10 ³	6.00×10 ⁴	0.250
SG26	1.69×10 ⁴	1.47×10 ⁵	0.380
SG33	5.11×10 ⁴	3.42×10 ⁵	0.600
SG46	2.42×10 ⁴	1.49×10 ⁶	1.240
SG55	2.29×10 ⁵	2.28×10 ⁶	1.500
SE15	2.71×10 ³	2.36×10 ⁴	0.147
SE23, SC23	1.44×10 ⁴	1.37×10 ⁵	0.410
SE30, SC30	3.88×10 ⁴	3.14×10 ⁵	0.560
SE45, SC45	1.45×10 ⁵	1.26×10 ⁶	1.110

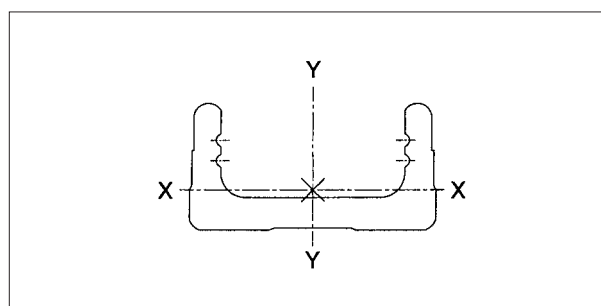

OPTION AND MANUFACTURING BY ORDER

Front matter

Category	Item		SG series					SE series				SC series			
			SG20	SG26	SG33	SG46	SG55	SE15	SE23	SE30	SE45	SC23	SC30	SC45	
Option	Motor bracket configuration	Motor bracket	○	○	○	○	○	○	○	○	○	○	○	○	○
		Intermediate flange	○	○	○	○	○	○	○	○	○	○	○	○	○
		R0/RN type bracket (Note 1)	○	○	○	○	○	—	—	○	○	—	○	○	○
		Parallel motor mounting unit	—	—	○	○	—	—	—	○	○	—	○	○	○
	Type of cover	Without dustproof cover	○	○	○	○	○	○	○	○	○	—	—	—	—
		With dustproof cover	○	○	○	○	○	○	○	○	○	—	—	—	—
		Standard full-cover (Note 2)	—	—	—	—	—	—	—	—	—	○	○	○	○
		Full-cover with grease nipple (Note 2)	—	—	—	—	—	—	—	—	—	○	○	○	○
		Full-cover with wiper (Note 2)	—	—	—	—	—	—	—	—	—	○	○	○	○
		Full-cover with grease nipple and wiper (Note 2)	—	—	—	—	—	—	—	—	—	○	○	○	○
	Sensor	Photo-microsensor	○	○	○	○	○	—	○	○	○	○	○	○	○
		Proximity sensor	○	○	○	○	○	○	○	—	—	○	—	—	—
	Surface treatment (Note 3)		○	○	○	○	○	○	○	○	○	○	○	○	○
	Dust preventive grease (KURODA C-grease)		○	○	○	○	○	○	○	○	○	○	○	○	○
	Dowel pin hole		○	○	○	○	○	—	○	○	○	—	—	—	—
Manufactured by order (Note 8)	Intermediate stroke		●	●	●	●	●	●	●	●	●	●	●	●	
	Bellows		●	●	●	●	●	—	●	●	●	—	—	—	
	Grease filler hole (Note 4)		●	●	●	●	●	—	●	●	●	—	—	—	
	XY bracket		●	●	●	●	●	●	●	●	●	●	●	●	
	Motor assembling		●	●	●	●	●	●	●	●	●	●	●	●	
	Long rail configuration		●	●	●	●	—	●	●	●	●	●	●	●	
	Grease (Note 5)		●	●	●	●	●	●	●	●	●	●	●	●	
	Motor bracket configuration (Note 6)		●	●	●	●	●	●	●	●	●	●	●	●	
	Sensor (Note 7)		●	●	●	●	●	●	●	●	●	●	●	●	

○: Option —: Not available ●: Manufactured by order

- (Note 1) R0 type bracket is applied to SG series and RN type is applied to SE and SC series.
- (Note 2) Full-cover type with wiper and with grease nipple is applied only to SC series.
- (Note 3) Anti corrosive black coating (film thickness 1-2 μ m) is provided as surface treatment. For other types of surface treatment, consult KURODA.
- (Note 4) Grease filler hole for SG and SE series is applied to the configuration with sub-table.
- (Note 5) Any grease application other than standard or option grease applications will be provided on a manufactured by order basis.
- (Note 6) Ballscrew actuator with motor bracket or intermediate flange configuration other than standard or option configuration will be provided on a manufactured by order basis.
- (Note 7) Ballscrew actuator requiring a sensor other than option configuration or two sensors attached on both ends will be provided on a manufactured by order basis.
- (Note 8) For ballscrew actuators to be provided on a manufactured by order basis, specifications will be determined after consultation with customers. Please consult KURODA after completing the Specification Data Sheet attached at the end of this catalogue.

HOW TO INTERPRET MODEL NO.

Model No.	Lead	Slide block	Guide rail length	Performance grade	Motor bracket configuration	Type of cover	Sensor	Surface treatment	Grease	Dowel pin hole
SG33	10	A	500	P	A1	C	C	N	N	PS
①	②	③	④	⑤	⑥	⑦	⑧	⑨	⑩	⑪
Model No. of Main Body					Model No. of Option					

① Model of ballscrew actuator

The 2-digits number represents height of mounting surface, from the bottom face of guide rail to top face of slide block. (For SG/SE series with dustproof cover and SC series, Model No. of the unit used as base of the body is shown.)

SG series	SG20	SG26	SG33	SG46	SG55
SE/SC series	SE15	SE/SC23	SE/SC30	SE/SC45	

② Lead of ball screw

Permissible speed varies depending on the lead. For more information, refer to dimensions of each series.

Lead	SG series					SE/SC series			
	SG20	SG26	SG33	SG46	SG55	SE15	SE/SC23	SE/SC30	SE/SC45
1mm	○					○			
2mm		○				○	○		
4mm								○	
5mm	○	○	○				○	○	○
10mm			○	○				○	○
20mm			○	○	○				○

③ Variation of slide blocks and number of blocks to be mounted

For configuration with 2 slide blocks, a driving block and driven block in combination is mounted. For more information, refer to dimensions of each series.

④ Guide rail length

For more information, refer to dimensions of each series. Please note that the guide rail length is different from overall length or maximum stroke length of actuator.

Model No.	Standard guide rail length									
SE15	100	150	200							
SE23, SC23	150	200	250	300						
SE30, SC30	150	200	300	400	500	600	700	750		
SE45, SC45	540	640	740	840	940					
SG20	100	150	200							
SG26	150	200	250	300						
SG33	150	200	300	400	500	600*				
SG46	340	440	540	640	740	840*	940*	1040*	1140*	1240*
SG55	980	1080	1180	1280*	1380*					

- Asterisk (*) item in the above table applies only to performance grade H.
- For long rail configurations, please consult KURODA.

⑤ Performance of ballscrew actuators, including various positioning accuracy indicators and traveling parallelism

For more information on accuracy, refer to a table of accuracy information for each series.

⑥ Motor bracket configuration

Intermediate flange may be used in combination with basic configuration. For more information, refer to a table of motor bracket configurations and motor option for each series.

⑦ Type of cover

For more information, refer to dimensions of each series.

⑧ With or without sensor / type of sensor

For more information, refer to dimensions of each series.

⑨ With or without surface treatment applied on guide rails and ball screws

With standard specifications (Symbol N), only guide rails are treated with black coating (except for guide rails made from stainless steel).

⑩ Type of grease applied on slide blocks and ball screws of ballscrew actuators

With standard specifications, Multemp PS No.2 Grease (KYODO YUSHI CO., LTD.) is contained.

⑪ With or without dowel pin holes

The column will be left blank (no symbol) if actuator is without dowel pin holes. For more information, refer to configuration drawings for each series.



Front matter



FOR SAFETY USE

Be sure to read the following instructions before use.
For common instructions, refer to the text of this catalog.

The following safety precautions recommend the correct usage of our products to prevent an injury and a damage. These precautions are classified into 3 categories : "DANGER", "WARNING" and "CAUTION" according to the degree of possible injury or damage and the degree of impendence of such injury or damage.
Be sure to follow all these precautions, as they include important contents regarding safety.

 DANGER	 WARNING	 CAUTION
Indicates an impending hazardous situation that may arise due to improper handling or operation and could result in a serious injury or death.	Indicates a potentially hazardous situation that may arise due to improper handling or operation and could result in a serious injury or death.	Indicates a potentially hazardous situation that may arise due to improper handling or operation and could result in an injury or property damage only.

Be sure to obey "Labor Safety and Sanitation Law" and other safety rules and regulations in addition to these precautions. There is some situation that may lead to a serious result according to circumstances, even if it is mentioned in the category of "CAUTION". Be sure to follow these precautions, as they contain important matters.

 WARNING
<ul style="list-style-type: none"> • Select a ballscrew actuator properly. As operating conditions for products mentioned in this catalog are diversified, the applicability of ballscrew actuator to the intended system should be determined by the total system designer or the person who determined specifications for such system after conducting an analysis and testing as necessary. The person who determined the applicability of the system shall be responsible for assuring the intended system performance and safety. When configuring a system, the system designer should thoroughly examine all specifications for such a system by referring to the latest product catalog and data, and also take into consideration the possibility of equipment troubles. • The ballscrew actuator should be handled by persons who have sufficient knowledge and rich experience. Thoroughly read this catalog and operation manual before use. <ul style="list-style-type: none"> · Never disassemble the ballscrew actuator. Dust can enter the inside, degrading the accuracy of the module and causing an accident. When the ballscrew actuator has been disassembled from necessity, return it to our company for repair and reassembling. (In this case, repairing charges are required.) · When mounting a ballscrew actuator to a machine and dismantling it from machine, check that a fall prevention means has been taken and the moving part of the machine has been fixed beforehand. • When using the ballscrew actuator in the following conditions or environments, take the proper safety measures and consult KURODA beforehand. <ul style="list-style-type: none"> · Conditions and environments other than specified and outdoor use. · Applications to nuclear power equipment, railroads aircraft, vehicles, medical equipment, equipment connected with food and drink, and the likes. · Applications which require extreme safety and will also greatly affect men and property. • During operation, make sure to keep your hands away from either of stroke ends, where slide block moves, to prevent your finger from being caught. • During operation, make sure to keep your hands away from screws and axis terminals of ball screw shaft, which are rotating parts, to prevent your hands from being caught. • Pay adequate attention not to allow the actuators to be used for military purpose including for arms and weapons.



BALLSCREW ACTUATOR/COMMON INSTRUCTIONS

Be sure to read the following instructions before use.
Also refer to "FOR SAFETY USE".

DESIGN

WARNING

- Especially when there is the possibility that the ballscrew actuator is dangerous to the human body, provide it with a protective cover.

When there is the possibility that the load and the moving part of the ballscrew actuator are dangerous to the human body, design the structure to prevent the human body from touching such load and moving part directly.

- Firmly tighten the fixed part and connection of the ballscrew actuator. Improper mounting of the body may adversely affect safety and accuracy according to circumstances.
- Take into consideration the behavior of the ballscrew actuator in an emergency.

When the machine is immediately stopped in an emergency by a person or by a safety device in case of power failure or system trouble, the motion of the module can injure the human body and can damage the machine. So design the machine to prevent an injury to the human body and a damage to the machine.

SELECTION

WARNING

- Check specifications.
Be sure to use the ballscrew actuator within the given specifications.
- When selecting a rigid type as coupling for connecting a motor, consult KURODA.

MOUNTING

CAUTION

- Be careful not to dent and flow the body and the mounting surface of the table, side cover, and center sheet.

Such dent or flaw will degrade parallelism of mounting surface, resulting in rattling of the guide and increased slide resistance. Note that, since the center sheet of SC series are very thin, such dent or flaw may ruin its dust preventive capability or lead to damage of the sheet function.

- When connecting the ballscrew actuator to a load with an external support or guide, do so in accordance with a proper connecting method and perform centering satisfactorily.
- When mounting a load, do not apply an excessive shock or moment.

If the ballscrew actuator receives external force exceeding the permissible moment, the guide will loosen and sliding resistance will increase.

- Do not start the system until it is confirmed that the ballscrew actuator works properly.

After mounting the ballscrew actuator, perform an appropriate functional test and make sure that it is correctly mounted and works safely without fail before starting the system.

- Although corners of components, such as motor bracket, housing, side cover, and center sheet, are beveled, pay enough attention not to hurt yourself when handling them.

OPERATING ENVIRONMENT

DANGER

- Do not use the ballscrew actuator in a place where an explosive atmosphere exists.

WARNING

- Do not use the ballscrew actuator in an atmosphere containing corrosive gases, chemicals, seawater, water and vapor and in a place where it can be stained with such matters.
- When using the ballscrew actuator in a place where it is exposed to dust, cuttings, spatters, etc., fit a protective cover or other protector.
- Do not use the ballscrew actuator in a vibratory or shockable place ; otherwise causing a bad condition or breakdown.

When using the ballscrew actuator in such an environment, consult KURODA.

CAUTION

- Since the SC series is equipped with sheet magnet on side covers for attracting center sheet to keep its position, be careful not to have the magnet contaminated with iron power or metallic fragments.

LUBRICANTS

CAUTION

- Unless otherwise specified, the nut contains Multemp PS No.2 Grease (KYODO YUSHI CO., LTD.) as a lubricant.

- Checking and supplying lubricant

Check the lubricant 2 to 3 months after the ball screw is used for the first time. If it is extremely dirty, wipe off old grease and apply new grease. Then, check and supply the lubricant once every year as a general rule. However, as the service life of lubricants varies according to operating conditions and environment, adjust the intervals properly.

When feeding additional grease (lubricant), use the same brand of grease as initially contained.

With SC series, a central grease filler hole (M3) is provided on side surface of table, making it possible for the grease to be supplied to ball screw and guide through the filler hole.

Supply additional grease as necessary, preferably with the interval indicated above. When adding grease, 2 dispenses by grease gun (approx. 1 to 2 cc) should be supplied.

After supplying additional grease, operate the table to the extent of full stroke to apply the grease over the component. Wipe off excess grease attached around the central grease filler hole.

- Do not use at high temperature over 60 celsius degree.

As resin is used in ballscrew actuator, use at lower temperature than 60 celsius degree. For ballscrew actuator with sensor, use at lower temperature than 55 celsius degree.